

## INSTALLATION AND MAINTENANCE INSTRUCTIONS

### For Chemline A- & Q-Series Actuator with Digital (AC) Positioner

#### General:

The Digital High-performance position AC Controller is designed to control quarter-turn AC actuators, providing 450 points of resolution to those actuators ranging from 2 seconds to 120 seconds and rated for 25% duty or more. The DHC has many automatic advanced features that will enhance any actuator while making it easy to install and set up.

The simple 3-button control is used to configure all parameters the unit needs for a wide variety of applications, and allows the *open* and *closed* positions to be easily set for direct or reverse action without any rewiring. The unit can be configured for various command types (4-20 mA, 1-5 VDC, 0-5 VDC, 0-10 VDC or digital commands) and its default operation upon loss of command signal.

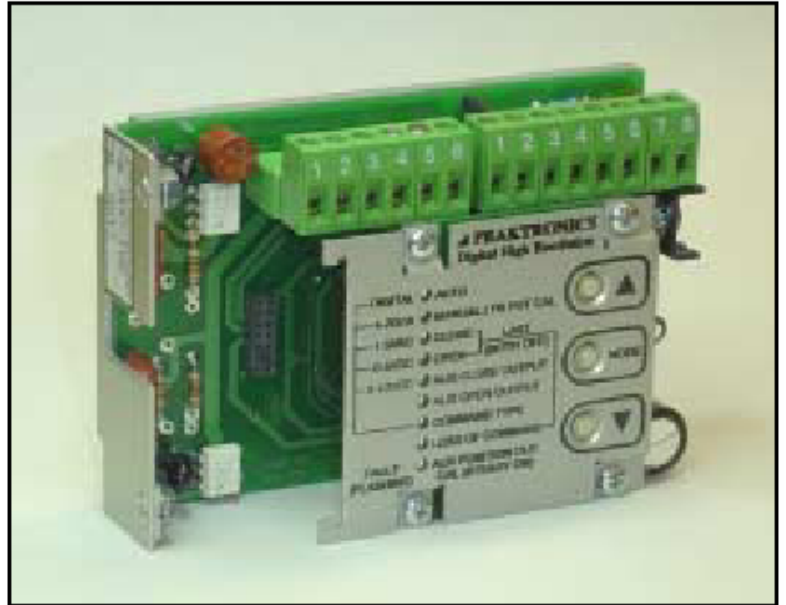

Various option modules are easily plugged into the unit, providing other features such as position feedback signal (current or voltage), auxiliary switches, fault relay contact, or digital communications. A wide range of data is accessible through a digital communications module, providing additional control or information. In the simplest application, only the *closed* and *open* positions need to be set and the unit automatically and continuously sets all other parameters when placed in the AUTO mode.

#### Features:

- Positions to  $\pm 0.1^{\circ}$  with quarter-turn actuators ranging from 2 seconds to 90 seconds.
- Adaptive control feature continuously adjusts for load and actuator conditions, eliminating calibration procedures and auto-cal operations.
- 3-button control provides easy setup and eliminates the need for instrumentation.
- Polarity detection feature allows direct or reverse acting operation without re-wiring.
- Electronic brake feature can eliminate the need for a mechanical brake in many applications, and extends mechanical brake life when used.
- Stall detection feature protects actuator motor from a stall condition.
- Automatic duty cycle control feature prevents shutdown of a process due to a thermal overload of the actuator motor, and allows actuators rated for 25% duty or more to be safely used.
- Operating temperature range of  $0^{\circ}$  to  $60^{\circ}\text{C}$ .

## Calibration & Adjustment Instructions A- & Q- Series Actuator w/Digital Positioner

### Requirements:

**CAUTION:** These units are intended for mounting in an appropriate enclosure to avoid electrical shocks. High voltages are present on the outside of the unit when power is applied. AC power should be disconnected prior to any wiring of these units. A heater/thermostat should be used where condensation may occur. Proper voltage must be supplied or resulting damage to the actuator and/or the positioner could ensue.

The digital positioner is rated for motors with up to 5A running currents and comes in three versions to accommodate different voltage applications (110VAC, 220VAC and 24VAC). The unit is easily mounted with 2 screws and is equipped with removable screw terminals for easy field wiring.

### QuickCal Procedure:

The following is a quick calibration procedure only. Please read the following pages to ensure that ALL of the selectable features are understood and selected if required.

1. With AC power to terminals #1 (neutral) and #2 (hot) at location J2, push MODE button until “MANUAL/FB POT CAL” LED is illuminated.
2. Use arrow buttons (▲ and ▼) to position the actuator to mid-stroke.

If LED is solid, proceed to step 4.

3. Rotate potentiometer gear until LED is no longer flashing, but on solid. Keep in mind that the LED will flash at a slower rate when farther away from mid-stroke and at a faster rate when closer to mid-stroke.
4. Push MODE button until the “CLOSE” LED is illuminated. Use arrow buttons (▲ and ▼) to drive the actuator to the closed position.
5. Push MODE button until the “OPEN” LED is illuminated. Use arrow buttons (▲ and ▼) to drive the actuator to the open position.
6. Push MODE button until the “COMMAND TYPE” LED is illuminated. Use arrow buttons (▲ and ▼) to select the appropriate signal (4-20 mA, 1-5 VDC, 0-5 VDC or 0-10 VDC).
7. Push MODE button until the “LOSS OF COMMAND” LED is illuminated; this setting drives the actuator to a predetermined position upon loss of command. Use arrow buttons (▲ and ▼) to select the appropriate position (open, closed or last position).
8. Push MODE button until the “AUTO” LED is illuminated. QuickCal is now complete and the unit is ready for operation.
9. Connect signal/command wires to terminal #4 (signal ground) and either terminal #5 or #6 (depending on command signal) at location J2.

## Calibration & Adjustment Instructions A- & Q- Series Actuator w/Digital Positioner

### **Power/Signal:**

Power is connected to pin 1, 2 and 3 on terminal J2 as shown in the block diagram. The fuse installed on the unit is rated for the maximum output current that can be safely delivered by the AC outputs. Replacement fuses must not exceed the maximum rating to prevent damage to the unit.

An appropriate command signal, either 4-20 mA, 1-5 VDC, 0-5 VDC or 0-10 VDC, should be connected to pin 5 or 6, while using pin 4 as the return signal ground. The positioner must be configured for the type of command signal that is to be used (see header COMMAND TYPE).

Pin 7 provides an auxiliary +5V output, which can be used to connect a command potentiometer. By connecting one end of a potentiometer to pin 7, the other end to pin 4, and the wiper to pin 6, a local control knob can be implemented. Pin 8 provides an auxiliary +15VDC output, which can be used to power an input or output 4-20 mA transmitter.

### **Actuator:**

The actuator motor and feedback potentiometer are connected to terminal J1 as shown in the block diagram. The motor neutral wire must be connected to pin 2, while one motor winding is connected to pin 1 and the other winding to pin 3. The feedback potentiometer wiper must be connected to pin 5, while one end is connected to pin 4 and the other end to pin 6. The polarity detection feature automatically determines which motor winding to control based on where the *open* and *closed* positions are set; this feature also eliminates the need to rewire the unit for direct or reverse acting applications.

When the ▲ and ▼ buttons are used to control the actuator, the ▲ button will turn on the motor winding connected to pin 1, while the ▼ button will turn on the motor winding connected to pin 3. See MANUAL/FB POT CAL for more.

### **Override:**

Terminal J7 provides a simple 2-wire connection that can override the positioner to perform a variety of external control functions. Using an appropriate interface module, commonly used auto/manual station switches are easily implemented with low voltage/low current switches. See Special Applications for more details. The factory-installed jumper between pins 1 and 2 enables normal operation and must be installed if the external override functions are not used.

## Calibration & Adjustment Instructions A- & Q- Series Actuator w/Digital Positioner

### **Mode:**

The MODE button is used to select the desired function of operation. When the MODE button is pressed, the unit will switch to the next function and the appropriate LED indicator will turn on to let the user know which function is selected. Except for the MANUAL/FB POT CAL mode, the associated mode indicator will be steady on; for some of the modes, other indicators will flash to indicate specific settings associated with that mode. Each of the modes is described in more detail in the following sections.

If a 0-5 VDC or 0-10 VDC command signal is used, the LOSS OF COMMAND function cannot be used and the MODE button will skip over the LOSS OF COMMAND mode (see COMMAND TYPE). When the OVERRIDE mode is enabled (see OVERRIDE MODE) the MODE button is disabled and the Manual/Pot Cal indicator will turn on steady.

### **Adjust up and Adjust down:**

The adjust ▲ and adjust ▼ buttons are used to adjust the setting of any given function. When a function is selected by the MODE button, the ▲ and ▼ buttons will affect that function only. Note that the AUTO mode does not have any adjustable setting, and therefore, the ▲ and ▼ buttons have no effect. Also, the ▲ and ▼ buttons are disabled in the OVERRIDE mode.

### **Override Mode:**

The OVERRIDE mode is not selected by the MODE button and can be enabled at anytime by connecting a resistance greater than 250 ohms to the Override Input (J7 pin 1 and pin 2). While the OVERRIDE mode is enabled, the MODE button and ▲ and ▼ buttons are disabled and the MANUAL POT CAL indicator will turn on steady to indicate that the unit is being controlled by the Override Input. Shorting J7 pin 1 to pin 2 returns the unit to normal operation and to the previously selected mode. Note that earlier models may not have connector J7, and therefore do not have the OVERRIDE mode feature.

Controlling the positioner from the Override Input is accomplished by connecting a specify resistance to select a specific operation. The table below defines the operation and their associated resistance. See Special Applications for details on using the Override Input for an Auto/Manual Station.

RESISTANCE	OPERATION
>4.3K ohms	Off
3.3K ohms ± 5%	Latch
2K ohms ± 5%	Open
1.2K ohms ± 5%	Close
510 ohms ± 5%	Stop

## Calibration & Adjustment Instructions A- & Q- Series Actuator w/Digital Positioner

The OPEN function operates the motor in the *open* direction as set by the OPEN mode, while the CLOSE function operates the motor in the *closed* direction as set by the CLOSE mode. The LATCH function will maintain the previously selected function; this allows momentary switches to be used for the OPEN and CLOSE functions. The OFF and STOP functions turn the motor off, which also unlatches the OPEN and CLOSE functions.

Note that the OPEN and CLOSE functions may work in reverse until the *open* and *closed* positions are set by the OPEN and CLOSE modes. The positioner will automatically turn the motor off when the *open* and *closed* positions are reached. However, if a feedback fault occurs (see FAULT INDICATOR), the motor will be turned on for a period of 15 minutes in the selected direction. For this reason, limit switches should be used when using the OVERRIDE mode and should be set to a position acceptable for the application. The 15-minute period can also be terminated using the OFF and STOP functions. The motor is also automatically turned off if the positioner detects a stall (see STALL DETECTION). An OPEN or CLOSE operation can be attempted again after switching to the OFF, LATCH or STOP functions first.

### **Auto:**

The AUTO function is the normal mode of operation of the positioner; all the other functions are used to set up the unit. While in AUTO, the unit can be controlled by various external signals, some of which can be selected by the COMMAND INPUT function. When the unit is not in the AUTO mode, all external controls described below will be disabled.

Once the *open* and *closed* positions have been set, the AUTO mode will control the position of the actuator according to the command input signal. For an input signal of 4 mA (for 4-20 mA input), 1V (for 1-5 VDC input), 0V (for 0-5 VDC or 0-10 VDC input) or 0% (for digital input), the unit will position the actuator to the *closed* position as set by the user. Conversely, an input of 20mA, 5V, 10V or 100% will position the actuator to the defined *open* position.

When the positioner is configured to use a 4-20 mA, 1-5 VDC, 0-5 VDC or 0-10 VDC command, the command signal should be connected to the appropriate pin on terminal J2 – note that the unused input pin must be left unconnected. When the positioner is configured for a digital command type, an appropriate communications option module must be installed. A communications module may be installed when using one of the analog command types and can be used to override the analog command. The AUTO indicator will flash whenever the communications module is controlling the unit.

### **Manual/FB Pot Cal:**

The MANUAL/FB POT CAL function allows manual operation of the actuator by using the ▲ and ▼ buttons without affecting any other settings within the positioner. When the ▲ button is pressed, the motor winding connected to J1-1 is turned on while the ▼ button turns on the J1-3 winding. Whether the actuator moves toward the *open* or *closed* position depends on which motor winding is connected to J1-1 and J1-3.

## Calibration & Adjustment Instructions A- & Q- Series Actuator w/Digital Positioner

The POT CAL feature provides an indication of the feedback potentiometer's setting. When the MANUAL/POT CAL function is selected, the Manual/Pot Cal indicator will turn on – it may flash or be steady, depending on the actuator position. The indicator will be on steady whenever the positioner detects that the feedback potentiometer is at midrange of its rotation. As the actuator moves, causing the feedback potentiometer to move away from midrange, the indicator will begin to flash, at a decreasing rate as the actuator moves further away from midrange.

By using the ▲ and ▼ buttons to position the actuator to mid-stroke (halfway point between the desired *open* and *closed* positions), the feedback potentiometer can then be adjusted until a steady light occurs. This ensures that the feedback potentiometer has maximum range to reach the *open* and *closed* positions.

### ***Open:***

The CLOSE function is used to set the desired *closed* position; however, prior to doing this, the feedback potentiometer should be checked for optimum position (see MANUAL/POT CAL), and the limit switches should be set outside of the operating range (see STALL DETECTION FEATURE). In the CLOSE function, the ▲ and ▼ buttons are used to set the actuator to any desired position, and upon pressing the MODE button (to select the next function, in this case, OPEN) the positioner will retain the setting as he defined *closed* position.

Upon selecting the CLOSED function, the positioner will begin moving the actuator to the previously set *closed* position; it is not necessary to make an adjustment if the unit has been previously set to the desired position. A command signal input of 4mA, 0V, 1V or 0% automatically corresponds to the defined *closed* position.

### ***Closed:***

The OPEN function works the same way as the CLOSE function with the exception that the ▲ and ▼ buttons are used to set the desired *open* position. As with the CLOSE function, upon selecting the OPEN function, the actuator will move to the previously set *open* position. Once the desired position is set, the positioner will automatically correspond to a command signal input of 20mA, 5V, 10V or 100% to the *open* position.

### ***Auxiliary Close Output:***

The AUX CLOSE OUTPUT function is used to set an optional output setting that is associated with the *closed* position – an appropriate relay option module is required to use this output. The ▲ and ▼ buttons are used to set the actuator to a desired position. Whenever the actuator position falls between the defined *closed* position and the Aux Close position, the AUX CLOSE OUTPUT indicator will flash. Additionally, the positioner will turn on a relay output on the optional relay module – the output can be used to drive an alarm or merely act as an auxiliary limit switch.

Upon selecting the AUX CLOSE OUTPUT function, the positioner will begin moving the actuator to the previously set position. It is not necessary to make an adjustment if the unit has been previously set to the desired position.

## Calibration & Adjustment Instructions A- & Q- Series Actuator w/Digital Positioner

### ***Auxiliary Open Output:***

The AUX OPEN OUTPUT function is used to set an optional output setting that is associated with the *open* position – an appropriate relay option module is required to use this output. The ▲ and ▼ buttons are used to set the actuator to a desired position. Whenever the actuator position falls between the defined *open* position and the Aux Open position, the AUX OPEN OUTPUT indicator will flash. Additionally, the positioner will turn on a relay output on the optional relay module – the output can be used to drive an alarm or merely act as an auxiliary limit switch.

Upon selecting the AUX OPEN OUTPUT function, the positioner will begin moving the actuator to the previously set position. It is not necessary to make an adjustment if the unit has been previously set to the desired position.

### ***Command Type:***

The COMMAND TYPE function is used to configure the command signal input for either 4-20 mA, 1-5 VDC, 0-5 VDC, 0-10 VDC or digital so as to match the type of command signal input being used. Upon selecting the COMMAND TYPE function, the Command Input indicator will turn on steady, while the indicator for the selected type will flash. Use the ▲ and ▼ buttons to select the desired input type. The selection will be saved when the MODE button is pressed, which will also advance the unit to the LOSS OF COMMAND function.

### ***Loss of Command:***

When using 4-20 mA, 1-5 VDC or digital input type for the command signal, the positioner will detect when the command signal is lost or out of range. A loss of command condition is detected whenever the input is disconnected, the input becomes less than 0.75 VDC or 3 mA, or the input becomes greater than 5.5 VDC or 22 mA. If the positioner detects a loss of command signal, the FAULT indicator will flash and the actuator will be moved to one of three preset positions: the *open* position, the *closed* position, or the position last attained prior to losing the command signal. The LOSS OF COMMAND function is used to set the desired default position.

When the LOSS OF COMMAND function is selected, the ▲ and ▼ buttons are used to set the default position. The positioner indicates the selected default setting by flashing the OPEN function indicator for the *open* default position, or it will flash the CLOSE function indicator for the *closed* default position. When neither indicator is on, then the “last position” default is selected.

When a 0-5 VDC or 0-10 VDC command signal is used, a loss of command signal cannot be detected. Therefore, the unit is configured for a 0-5 VDC or 0-10 VDC command signal (see COMMAND INPUT), the MODE button will not select the LOSS OF COMMAND function.

## Calibration & Adjustment Instructions A- & Q- Series Actuator w/Digital Positioner

### ***Auxiliary Position Out Cal:***

Note that the AUX POSITION OUT CAL indicator also serves as a FAULT indicator. When the indicator is on steady, the AUX POSITION OUT CAL function is selected. When the indicator flashes, a FAULT condition has been detected (see FAULT INDICATOR for details). The AUX POSITION OUT CAL function is used to calibrate an optional feedback transmitter output. An appropriate transmitter option module is required to use this feature.

When the AUX POSITION OUT CAL function is first selected (by pressing the MODE button while in the LOSS OF COMMAND function), the CLOSE indicator will flash, and the voltage or current associated with the *closed* position will appear at the option module output. If desired, the output can be adjusted (using the ▲ and ▼ buttons) to any value from 0 to 10 VDC (for a voltage output) or 0 to 20 mA (for a current output). The new setting is then associated with the *closed* position.

Pressing the MODE button again will leave the unit in the AUX POSITION OUT CAL function except that the OPEN indicator will flash, and the output voltage or current associated with the *open* position will appear at the option module output. Like the *closed* setting, the output can be adjusted to any voltage (from 0 to 0 VDC) or current (from 0 to 20 mA), and the new setting is then associated with the *open* position.

### ***Fault Indicator:***

The positioner detects various fault conditions that prohibit the unit from controlling the actuator. When any of these conditions are detected, the FAULT indicator will flash, and the motor outputs are turned off until all fault conditions have been corrected. If an appropriate relay option module is installed, the FAULT relay output on the option module will also turn off. A communications option module can read the specific condition(s) causing the fault. Note that a fault condition DOES NOT disable the motor outputs when manually controlling the actuator with the ▲ and ▼ buttons; while useful for troubleshooting, care should be exercised when operating the motor under a fault condition. The OVERRIDE mode can also operate the motor when a fault condition exists – see OVERRIDE MODE for details. The various fault conditions are described below.

**LOSS OF COMMAND** – If the command signal is disconnected or out of range, the fault indicator will remain on until the signal is reconnected or back in range.

**FEEDBACK POT FAULT** – A fault condition is detected whenever the feedback signal is out of range (that is, less than 5%, or more than 95%, of the potentiometer value), or when any of the potentiometer connections are broken. Normal operation resumes when the potentiometer is reconnected or back in range.

**MOTOR 1 STALL** – A fault condition is detected when no actuator motion is detected while the MOTOR 1 output is turned on. The fault condition will disable the MOTOR 1 output only, and the fault is cleared when the positioner detects a motion greater than 1.5<sup>0</sup> in either direction. The fault can be cleared if 1) the command signal commands a MOTOR 2 operation, 2) manual operation with the ▲ and ▼ buttons results in a motion greater than 1.5<sup>0</sup>, or 3) mechanical manual override forces the 1.5<sup>0</sup> motion, provided the mechanical motion is monitored by the feedback potentiometer.

## Calibration & Adjustment Instructions A- & Q- Series Actuator w/Digital Positioner

MOTOR 2 STALL - A fault condition is detected when no actuator motion is detected while the MOTOR 2 output is turned on. The fault can be cleared in the same way as a MOTOR 1 STALL (see above).

DOUBLE STALL – Both motor outputs will be disabled if the positioner detects no actuator motion in either direction. The command signal cannot clear this condition; only manual operation or a mechanical override can clear the fault. Alternatively, the positioner can be powered off and then on to temporarily clear the fault; however, this practice should be avoided without permanently correcting the cause of such a fault.

### ***Stall Detection:***

The stall detection feature of the positioner (see FAULT INDICATOR) essentially performs a similar function as commonly used torque switches.

The stall detection feature is useful for detecting when any of the motor wires become disconnected. However, limit switches employed in actuators essentially disconnect one of the motor windings. The positioner will detect this as a motor stall. To avoid this condition, the limit switches must be set outside of the operating range set by the OPEN and CLOSE functions.

### ***Electronic Brake:***

The electronic brake feature of the positioner provides highly reliable and accurate braking of the motor, and it is a key element in achieving high resolution. A mechanical brake can still be used without interfering with the positioner operation. Mechanical brakes can be useful for providing a holding brake in the event that power to the actuator is lost.

The electronic brake feature provides the primary braking of the motor, dramatically extending the life of a mechanical brake. Additionally, the adaptive control feature automatically compensates for changes in a mechanical brake's performance due to temperature or age.

Note that the actuator's limit switches should be set outside of the operating range set by the OPEN and CLOSE functions. The electronic brake feature degrades in performance if a limit switch is engaged. Limit switches exhibit wide variations, and the positioner can position the actuator more precisely at *open* and *closed* than the limit switches. A limit switch serves best as a failsafe device to protect against electrical failures in the actuator.

### ***Duty Cycle Control:***

The duty cycle control feature allows actuators rated at 25% duty or more to be safely used in automated valve applications. The positioner accurately monitors the relative heating of the motor and automatically duty-cycles the unit at a safe level when a process becomes unstable, or if a control loop is not properly set. While the thermal switch in the motor protects it from overheating, thermal switches can shut down the actuator for ten minutes or more.

## Calibration & Adjustment Instructions A- & Q- Series Actuator w/Digital Positioner

The duty cycle control feature allows continuous operation of the motor until it detects an excess heat buildup in the motor (usually well below the limit of the thermal switch). At that time, duty cycle operation is automatically enabled and continues until the motor cools enough to resume continuous operation. The duty cycle period is approximately 2 seconds with an on-time that automatically varies depending on the heating of the motor. While this slows down the actuator's operation, it does not impact the resolution performance of the positioner, and it prevents disruption of a process due to thermal switch shutdown.

### ***Option Modules:***

Various option modules can be plugged into the positioner's option module connector, terminal J3. Option modules provide additional features such as position feedback signals, auxiliary switch output, or digital communications. Contact Chemline for more information on available modules. Refer to the diagram below for installation instructions.

### ***Specifications:***

Power requirements:	110VAC, 220VAC, 24VAC 14VA typical (not including output load) 5A TR5 Slo-Blo fuse (replaceable)
Command signal input:	Input impedance: 20K ohms (1-5 VDC, 0-5 VDC, 0-10 VDC input) 251 ohms (4-20 mA input) Loss of command threshold: <0.75V or >5.5V (1-5 VDC input) <3 mA or > 22 mA (4-20 mA input)
Feedback signal input:	Input voltage: 0 to 2.5 VDC External feedback potentiometer: 1K ohm
Power supply outputs:	+15V OUT (J2-8): 125 mA maximum (not including option module) +5V OUT (J2-7): 5 mA maximum
AC motor outputs:	Off-state leakage current: <15 mA Maximum load current @ 60°C: 5A
Environmental:	Operating temp range: -32°F to 150°F Storage temp range: -40°F to 185°F Relative humidity range: 0 to 90 % (non-condensing)

## Calibration & Adjustment Instructions A- & Q- Series Actuator w/Digital Positioner

### Troubleshooting Guide:

PROBLEM	POSSIBLE CAUSE	REMEDY
No response from unit. (All lights are off).	No power.	Check power source.
	Excessive voltage applied to unit.	Replace unit.
	Blown or missing fuse.	Replace appropriate fuse; see "Specifications" above.
No response from unit. (MANUAL/FB POT CAL light is on).	Jumper wire on J7 terminal block is missing.	Install jumper wire on J7 terminal block.
	Auto/Manual station is improperly wired.	Check wiring on Auto/Manual station; see "Override Mode" above.
Actuator rotates backwards.	Actuator or valve is mounted incorrectly on coupling.	Remount actuator as necessary.
	Actuator needs to be reverse acting.	Refer to "Close" and "Open" modes above.
Actuator does not respond to input signal. (FAULT indicator constantly flashes).	No input signal connected when using 4-20 mA, 1-5 VDC or digital inputs.	Connect input signal and refer to "Loss of Command" above.
	Input signal polarity reversed.	Reverse input wires.
	Input signal wired to wrong terminal.	Check input signal wiring; refer to "Power/Signal" above.
	Feedback potentiometer, motor or solenoids are improperly wired.	Check wiring; refer to "Actuator" above.
	Feedback potentiometer out of range.	Refer to "Manual/FB Pot Cal" above.
	Defective feedback potentiometer.	Replace feedback potentiometer.
	Defective motor brake (holding motor).	Repair or replace motor brake.
Actuator does not respond to input signal. (FAULT indicator is off).	Defective motor (not turning).	Repair or replace motor.
	Motor turns, but actuator output shaft is not moving.	Repair or replace actuator.
	Closed and open positions are set to the same position.	Set closed and open settings; refer to "Close" and "Open" modes above.

## Calibration & Adjustment Instructions A- & Q- Series Actuator w/Digital Positioner

### Troubleshooting Guide:

FAULT indicator flashes after actuator reaches the fully closed or open position.	Closed or open limit switches set inside the operating range.  Torque switches trip due to mechanical end stops set inside operating range.	Adjust limit switch cams; refer to “Close” and “Open” modes above.  Adjust end stops; refer to “Close” and “Open” modes above.
AUX CLOSE OUTPUT or AUX OPEN OUTPUT indicators flash.	Actuator position is near closed or open.	If a transmitter/relay module is installed, set Aux Close and Aux Open positions; refer to “Aux Close Output” and “Aux Open Output” modes above.  If a transmitter/relay module is not installed, no remedy is required.
Actuator operates erratically. (FAULT indicator flashes erratically).	AC ripple induced on the command input signal.  Defective feedback potentiometer.  Loose feedback potentiometer or feedback potentiometer gears.  Sloppy gear tooth engagement.	Use equipment that isolates AC ripple from the command signal.  Replace feedback potentiometer.  Tighten feedback potentiometer and/or potentiometer gears.  Adjust feedback potentiometer gears for tight engagement.
Actuator hunts for position.	No motor brake or brake slipping.	Install or repair motor brake.
Triac output failure. (Motor buzzes and overheats).	Exposure to water from conduit entrance.  Exposure to water from unsealed actuator housing.  Exposure to moisture from condensate.  Corrosion from exposure to salts or acids.  External power applied to motor connections at J1-1 or J1-3.  Motor capacitor is defective, or has incorrect voltage rating.  Lightning or power surge.	Perform appropriate remedy, <u>then</u> replace unit:  Install drip loop at conduit entrance.  Inspect and/or replace actuator housing gasket; use actuator with proper sealing.  Use heater/thermostat and/or dessicant packets.  Use corrosion inhibitors and dessicant packets.  Remove connector J1 prior to applying external power.  Replace motor capacitor.  Replace unit.

# OUTLINE DIAGRAM

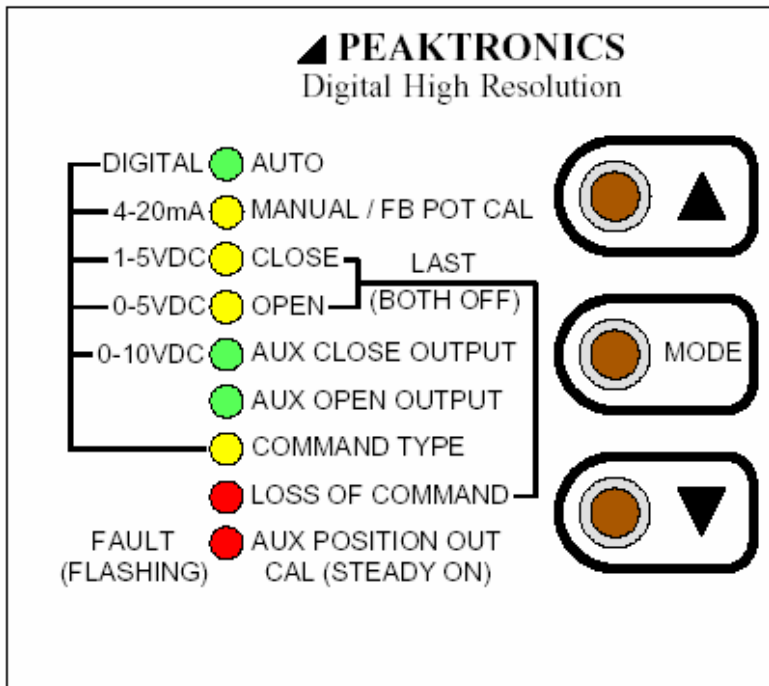

FRONT PANEL

## ELECTRICAL CONNECTIONS

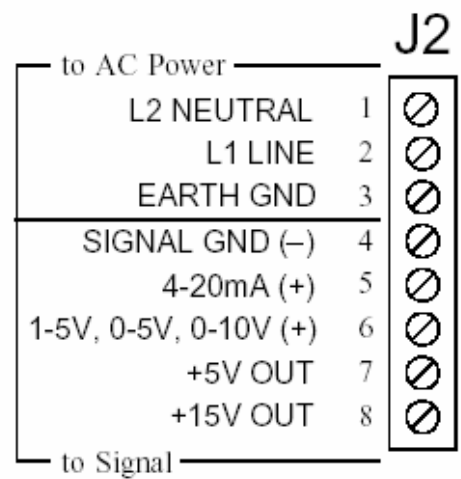
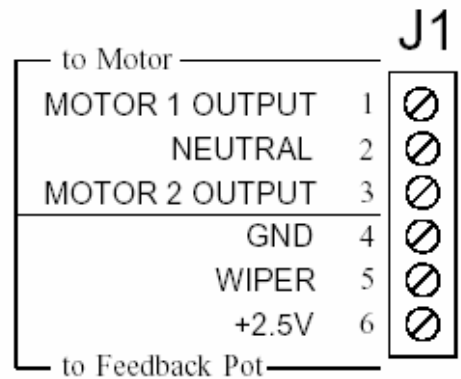

## J3

### OPTION MODULE CONNECTOR

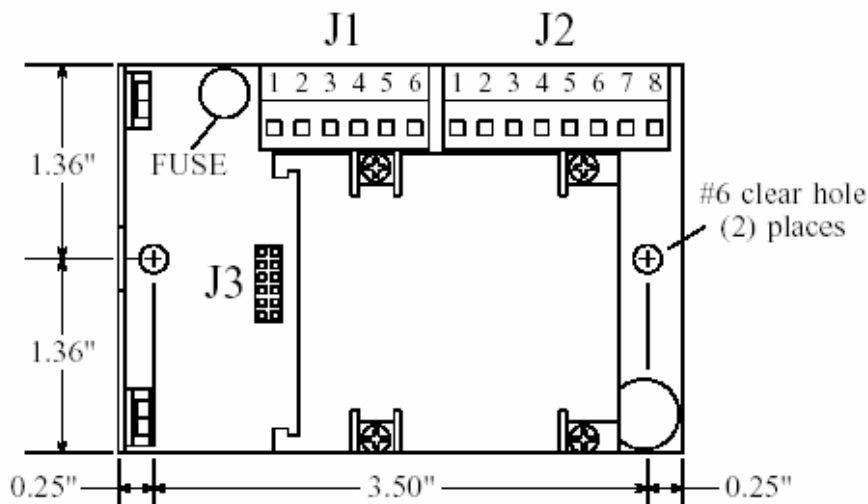
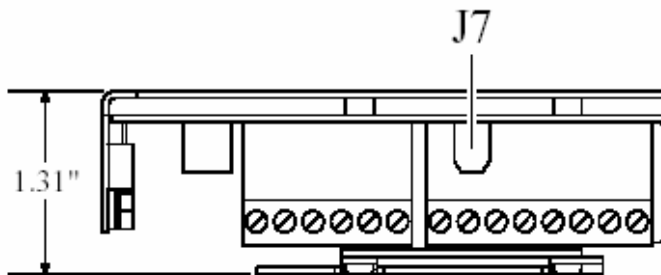
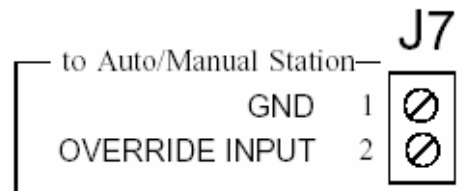

# BLOCK DIAGRAM

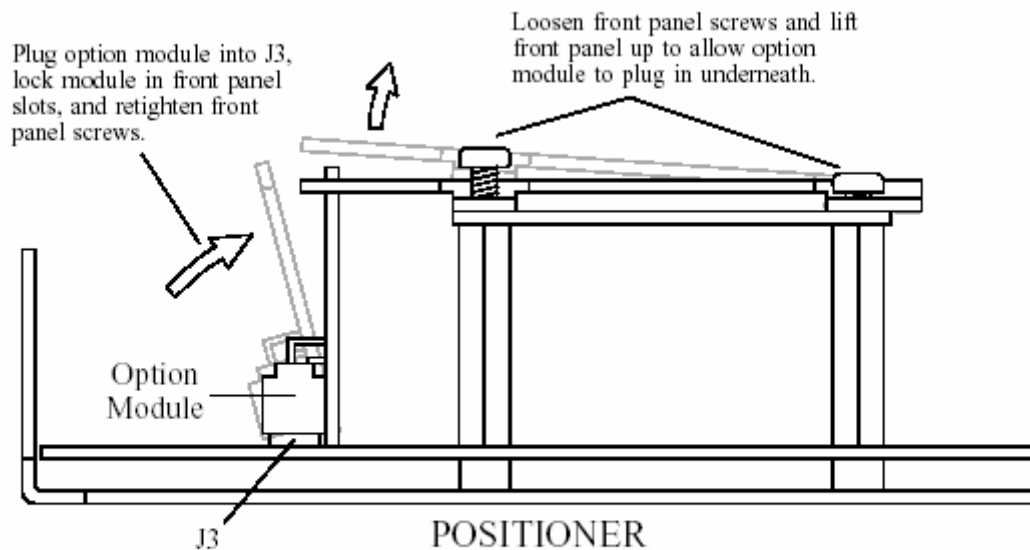
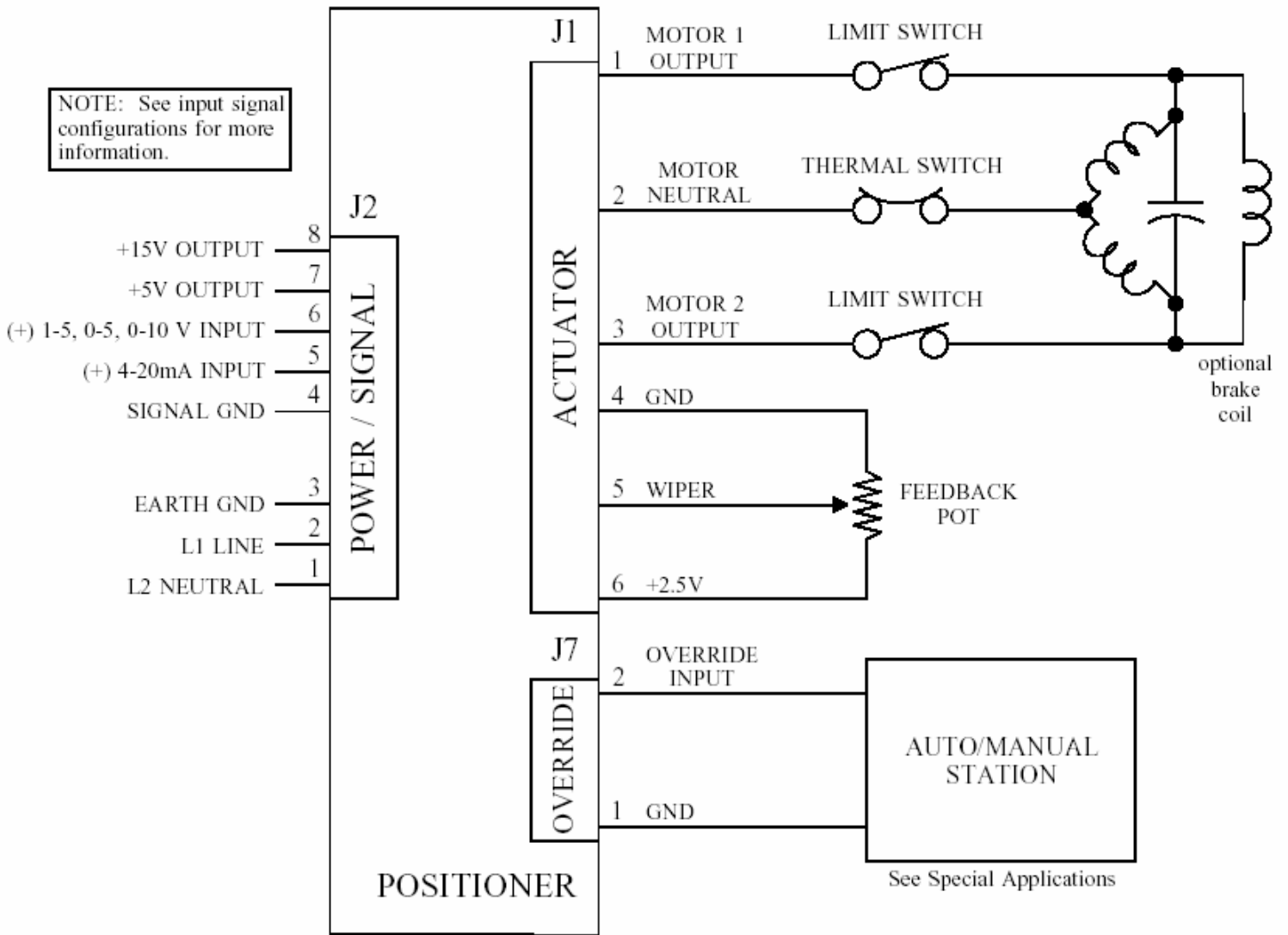

Installing an Option Module

# WIRING DIAGRAMS

## Input Signal Configurations

