

AA Series Air & Vacuum Release Valves

The Chemline AA Series Air and Vacuum Release Valve provides a controlled venting solution for larger diameter piping systems. This valve reduces the potential for water hammer incidents that occur when pressure builds up due to entrapped air. A unique two-stage ball stop prevents liquids from escaping while allowing high volume air release while the pipeline is under pressure, also at low pressure when it is being filled.

The vacuum release function allows air to re-enter the pipeline to prevent vacuum collapse.

PDCPD (Polydicyclopentadiene) is a polyolefin thermoset plastic. Valve parts are manufactured by a process called reaction injection moulding (RIM). PDCPD has excellent corrosion resistance and temperature ratings, very similar to those of polypropylene. It is durable material offering very high impact strength and a fraction of the weight of cast iron.

Light Weight

Durable

Features

High Impact Strength

Superior Exhaust Performance

- High discharge capacities
- Two-stage (high/low) exhaust function

Works at Low Pressures

- Half the minimum pressure compared to cast iron

Excellent Corrosion Resistance

- PDCPD (polydicyclopentadiene) material has chemical resistance similar to polypropylene

Top Entry

- Easy access to internal parts while valve is in line



CHEMLINE
Plastics Limited

Your Pipeline To Quality

PDCPD¹

SERIES: AA

SIZES: 1-1/4" & 3"

ENDS²: Threaded or Flanged

SEALS: EPDM



¹ PDCPD = Polydicyclopentadiene.

² 1-1/4" valves are threaded, 3" valves are flanged.

Air & Vacuum Release Valves

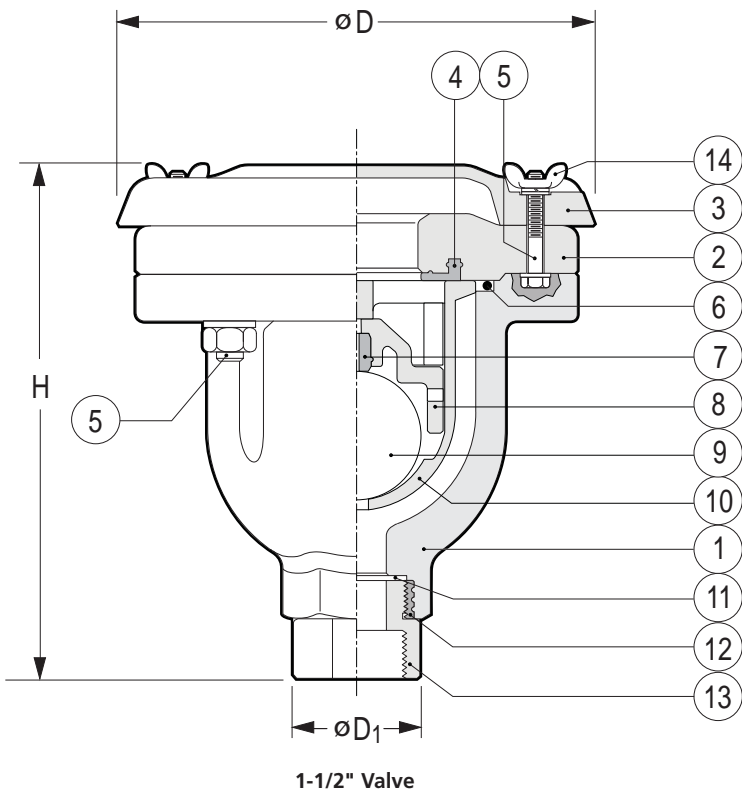
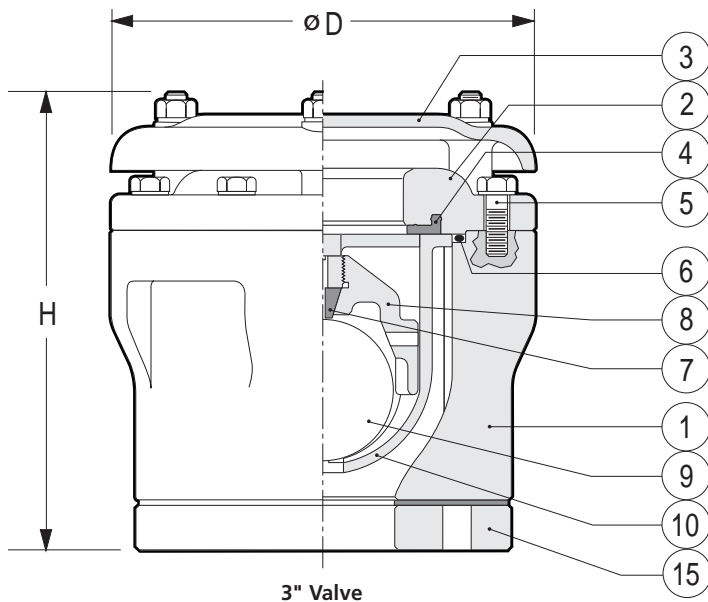

PARTS

▲ Recommended Spare Parts

No.	Part	Pcs.	Materials
1	Body	1	PDCPD ¹
2	Bonnet	1	PDCPD ¹
3	Cover	1	PDCPD ¹
4▲	Bonnet Seal	1	EPDM
5	Bolt & Nut Set	4	304 SS
6▲	Body O-Ring	1	EPDM
7▲	Float Seat	1	EPDM
8	Disc	1	PP
9	Float	1	PP
10	Guide	1	HI-PVC ²
11	Packing ³	1	EPDM
12	Body Insert ³	1	Copper Alloy
13	1-1/4" NPT End Connector ³	1	304 SS, PVC, PP
14	Wing-nut ³	4	304 SS
15	3" Flanged End Connector	1	304 SS

¹ PDCPD = Polydicyclopentadiene

² High Impact PVC

³ For 1-1/4" valve only

DIMENSIONS INCHES		WORKING PRESSURES PSI		TEMPERATURE RANGE °C (°F)		MAXIMUM AIR DISCHARGE CAPACITY CFM	WEIGHTS	
Size	Connection	D	H	Range	Range	CFM@1.42 psi ΔP/m ³ /h	LB.	KG
1-1/4"	Female Threaded	8.0	7.5	0.7 to 110	0°C (32°F) to 50°C (122°F)	185	6.5	2.95
3"	Flanged	9.5	9.0	0.7 to 185	0°C (32°F) to 50°C (122°F)	1,250	28.3	12.80

Air & Vacuum Release Valves



OPERATION

The valve features 2 air exhaust paths:

- high flow exhaust, sealed by rising Disc #8 seating on the Bonnet Seal #4
- low flow exhaust, sealed by the Float #9 seating on the float Seat #7

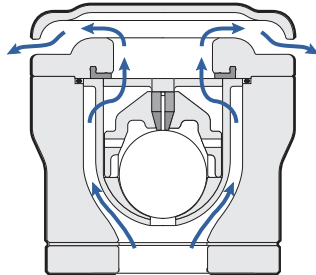

High flow air exhaust

- the pipe is empty and starts filling with liquid
- high flow exhaust path is open, disc #8 is floating on the rising liquid but not sealing on the bonnet seal #4 in this stage

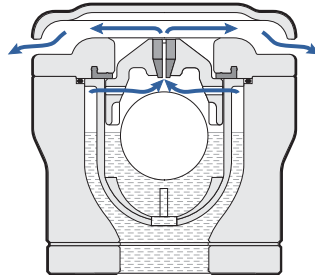

Low flow air exhaust prior to shut off

- the pipe is full
- the Disc #8 is sealing on the Bonnet Seal #4 closing the high flow exhaust
- the air trapped in the pressurized pipe will escape through the low flow exhaust path, Float #9 not sealing the Float Seat #7

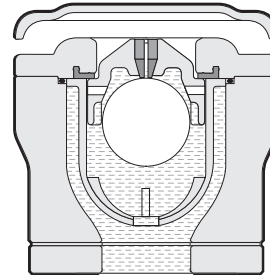

Shut-off

- all the air in the pipe was removed
- both high and low exhaust seals are sealing, the valve is fully closed

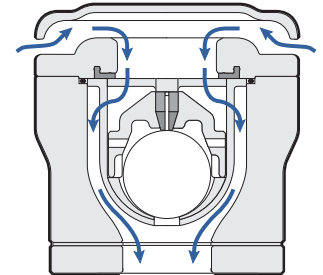

Air intake (vacuum release) function

- level of the liquid in the pipe drops
- Disc #8 is not sealing on Bonnet Seal #4, opening the high flow path and allowing atmospheric air to flow into the pipe

ORDERING EXAMPLE

Chemline Air Release Valves	AA	D	012	E	TS
Body Material	D – PDCPD				
Size	012 – 1-1/4" 030 – 3"				
Seals	E – EPDM				
Ends	1-1/4"	TS – Threaded SS TA – Threaded PVC TB – Threaded PP			
	3"	FS – Flanged SS			

Example: Chemline Type AA Air Release Valve, PDCPD, 1-1/4", with EPDM seals, threaded stainless steel end.