

Damper Butterfly Valves

Chemline PVDF Damper Butterflies have performed successfully for many years in the most demanding process control applications. With the PVDF disc and PVDF body and titanium shaft and no elastomer these valves are excellent in high temperature and abrasive applications. The precision machined disc allows for Class III leakage rates (as per ASTM B16.104 [1976]) for valves from 4" to 24" and Class II for the rest. Available from 1-1/2" to 24" sizes they can be used for a wide range of throttling applications.



PVDF

SERIES:	DFK
SIZES:	1-1/2" – 24"
BODY TYPE:	Semi lug Wafer ¹
MATERIALS:	
Body:	PVDF
Disc:	PVDF
Stem:	Titanium
Stem Seal:	PTFE 'V' Packing

Sizes up to 24"

Low Leakage (Class III)

High Corrosion Resistance

Features

Compact and Light Weight

High Corrosion Resistance

- Solid plastic body – no rust
- Polypropylene lever operators
- Gear operators have plastic housing and stainless steel trim and hardware

Abrasion Resistant

- Solid plastic PVDF disc available for high abrasion resistance

Easily Installed

- Full bolt hole circle makes installation and alignment easy

Class III Leakage Rates

- For valves 4" to 24" as per ASTM 16.104 (1976)

Class II Leakage Rates

- For valves 1-1/2" to 3" as per ASTM 16.104 (1976)



Full Bolt Circle for easy installation

DFK Series Butterfly Valves

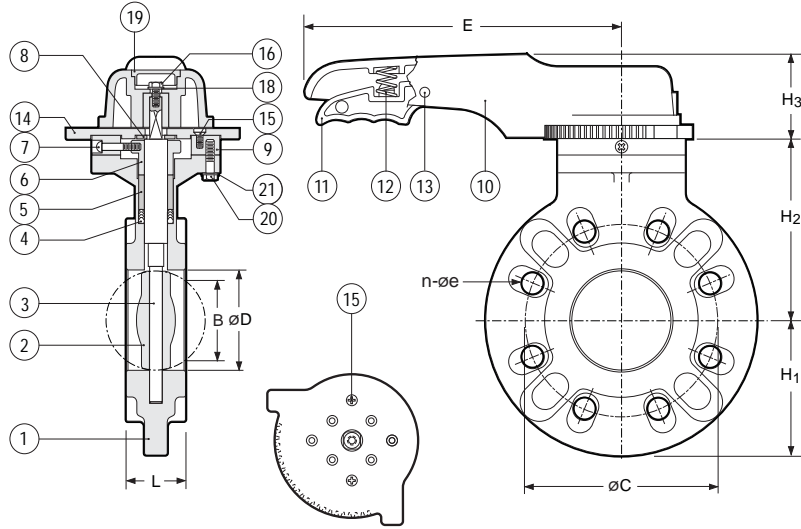

1-1/2" – 8" Lever Operated

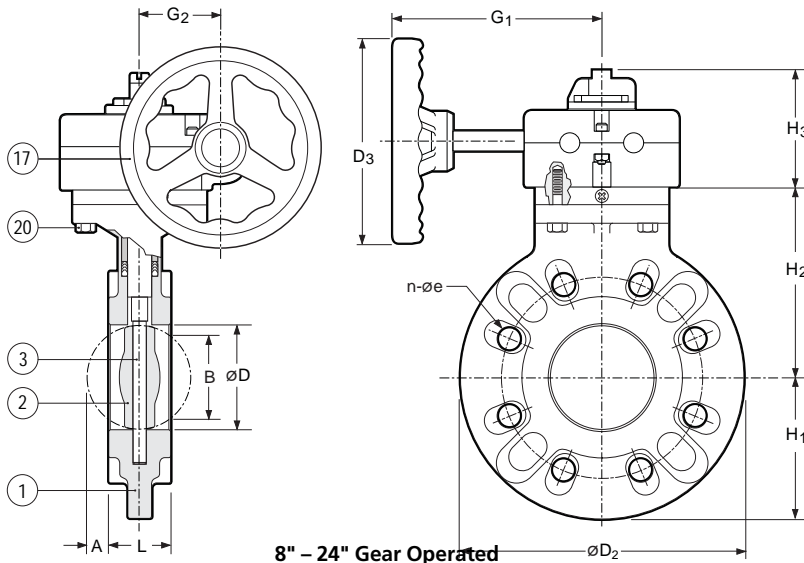

8" – 24" Gear Operated

PARTS

▲ Recommended Spare Parts

No.	Part	Pcs.	Materials
1	Body	1	PVDF
2	Disc	1	PVDF
3	Shaft	1	Titanium
4	V-Packing	1 set	PTFE
5	Bushing	1	PTFE (1-1/2"–14") PVDF (16"–24")
6	Gland	1	304 SS
7	Set Screw	1	304 SS
8	Shaft Retainer	1	PP
9	Spacer	2	PVC
10	Hand Lever	1	PP
11	Trigger	1	PPG
12	Spring	1	316 SS
13	Pin	1	PPG
14	Position Lock Plate	1	PPG
15	Plate Screw	2	304 SS
16	Hand Lever Bolt	1	304 SS
17	Gear Operator	1	Plastic housing, handwheel & SS hardware
18	Handle Lever Washer	1	304 SS
19	Hand Lever Cap	1	PPG
20	Bolt	4	304 SS
21	Washer	4	304 SS

DIMENSIONS INCHES

Size	L	A	B*	C	n	e	D	D ₂	D ₃	E/G ₁	G ₂	H ₁	H ₂	H ₃	I
1-1/2"	1.26	0.3	1.3	3.88	4	0.62	1.81	5.91	–	8.7	–	3.0	4.8	2.2	–
2"	1.38	0.4	1.8	4.75	4	0.75	2.24	6.50	–	8.7	–	3.3	5.2	2.2	–
2-1/2"	1.46	0.7	2.3	5.50	4	0.75	2.76	7.28	–	8.7	–	3.7	5.6	2.2	–
3"	1.46	0.8	2.7	6.00	4	0.75	3.07	8.31	–	9.8	–	4.2	6.2	2.2	–
4"	1.85	1.1	3.6	7.50	8	0.75	4.06	9.37	–	9.8	–	4.7	6.8	2.2	–
5"	2.24	1.4	4.6	8.50	8	0.88	5.12	10.39	–	12.6	–	5.2	7.4	2.7	–
6"	2.44	1.7	5.4	9.50	8	0.88	5.91	11.22	–	12.6	–	5.6	8.0	2.7	–
8" Lever	3.23	2.3	7.1	11.75	8	0.88	7.76	13.39	–	15.8	–	6.7	9.2	2.7	–
8" Gear	3.23	2.3	7.1	11.75	8	0.88	7.76	13.39	6.3	6.6	2.5	6.7	9.2	2.7	12.64
10"	3.78	3.0	9.0	14.25	12	0.98	9.72	15.98	6.3	6.6	2.5	8.0	9.5	4.7	14.02
12"	4.57	3.6	10.8	17.00	12	0.98	11.73	19.02	11.8	9.5	3.9	9.5	11.7	4.8	19.29
14"	4.57	4.5	12.9	18.75	12	1.14	13.66	20.47	11.8	9.5	3.9	10.2	11.8	4.8	20.35
16"	6.18	4.7	14.2	21.25	16	1.14	15.51	23.62	11.8	9.5	3.9	11.8	13.8	4.8	21.33
18"	6.57	5.4	16.1	22.75	16	1.26	17.36	24.80	16.1	12.6	4.3	12.4	14.6	5.0	25.60
20"	6.97	6.1	17.9	25.00	20	1.26	19.21	27.52	16.1	12.6	4.3	13.8	15.8	5.0	26.70
24"	7.76	7.9	22.3	29.50	20	1.38	23.62	32.01	16.1	12.6	4.3	16.7	18.3	5.0	29.30

* B = Minimum inside diameter (I.D.) of mating pipe. If I.D. of pipe is B dimension or less, the inside of pipe and must be chamfered or spacers provided. Consult Chemline.

DFK Series Butterfly Valves



WORKING PRESSURES PSI

NET WEIGHTS LB. **C_v VALUES** VS. DISC ANGLE

Size	-20-60°C	79°C	100°C	121°C	LB.	VS. DISC ANGLE			
	-4-140°F	175°F	212°F	250°F		0°	30°	60°	90°
1-1/2"	150	105	90	75	2.9	0.15	3.	42.	71.
2"	150	105	90	75	3.3	0.15	3.	54.	92.
2-1/2"	150	105	90	75	4.0	0.21	5.	83.	140.
3"	150	105	90	75	4.4	0.23	8.	130.	220.
4"	150	105	90	75	6.0	0.24	14.	225.	380.
5"	150	105	90	75	11.0	0.34	27.	430.	730.
6"	150	105	90	75	13.5	0.49	40.	650.	1,100.
8"L	150	90	75	60	21.4	0.73	90.	1,478.	2,500.
8"G	150	90	75	60	23.6	0.73	90.	1,478.	2,500.
10"	150	90	75	60	55.1	0.77	130.	2,128.	3,600.
12"	112	60	45	30	84.2	1.17	186.	3,050.	5,160.
14"	112	45	30	15	89.7	1.74	232.	3,806.	6,440.
16"	85	45	30	15	119.0	2.27	300.	4,929.	8,340.
18"	75	45	30	15	122.0	3.02	392.	6,436.	10,890.
20"	50	30	25	15	139.0	4.28	506.	8,310.	14,060.
24"	50	30	25	15	186.0	6.61	666.	10,934	18,500.

OPTIONS & ACCESSORIES

- **Electric or Pneumatically Actuated**
– Refer to separate data sheets
- **Municipal Operating Nut** for buried service
- **Chain Wheel Operator**
- **Gear Operator** on 1-1/2" – 6"
- **Locking Capability**
- **Shaft Extensions**
- **Lug Body Inserts** – Stainless steel lugs for dead end service
- **Limit Switches** for open and/or closed position indication

ORDERING EXAMPLE

Chemline Damper Butterfly Valves	DFK	K	100	G				
Body K – PVDF								
Size	015 – 1-1/2"	020 – 2"	025 – 2-1/2"	030 – 3"	040 – 4"	050 – 5"	060 – 6"	080 – 8"
	010 – 10"	120 – 12"	140 – 14"	160 – 16"	180 – 18"	200 – 20"	240 – 24"	
Operator	L – Hand Lever		G – Gear Operator					

Example: Chemline DFK Damper Butterfly Valve, PVDF body, 10", with PVDF disc, gear operator



55 Guardsman Road, Thornhill, Ontario, Canada, L3T 6L2
 Tel: 905-889-7890 request@chemline.com
 Fax: 905-889-8553 www.chemline.com



Your Pipeline To Quality Valves, Piping, Flow Meters and Controls