

Plugs for 3.0/3.3 Flow Sensors

Plugs are used to cap off tees or saddles (see pages 40-42) after a sensor is removed for relocation, repair or pipeline maintenance.

Materials: PVC, CPVC, PP, PVDF

Seals: EPDM, Viton®

Maximum Pressure:

150 psi @ 20°C (70°F). See page 43 for working pressures at higher temperatures.



MATERIALS

Item No.	Body Material	O-Ring
PLUGAE	PVC	EPDM
PLUGAV	PVC	Viton®
PLUGCE	CPVC	EPDM
PLUGCV	CPVC	Viton®
PLUGBE	PP	EPDM
PLUGBV	PP	Viton®
PLUGKV	PVDF	Viton®

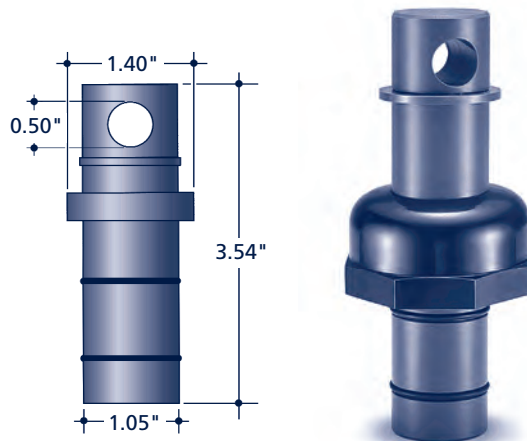

Working Pressure vs. Temperature

For Paddle Wheel Flow Sensors and Installation Fittings

To determine maximum recommended pressure at a given temperature check maximum pressure ratings of the sensor as well as installation fittings selected. The lower pressure rating applies.

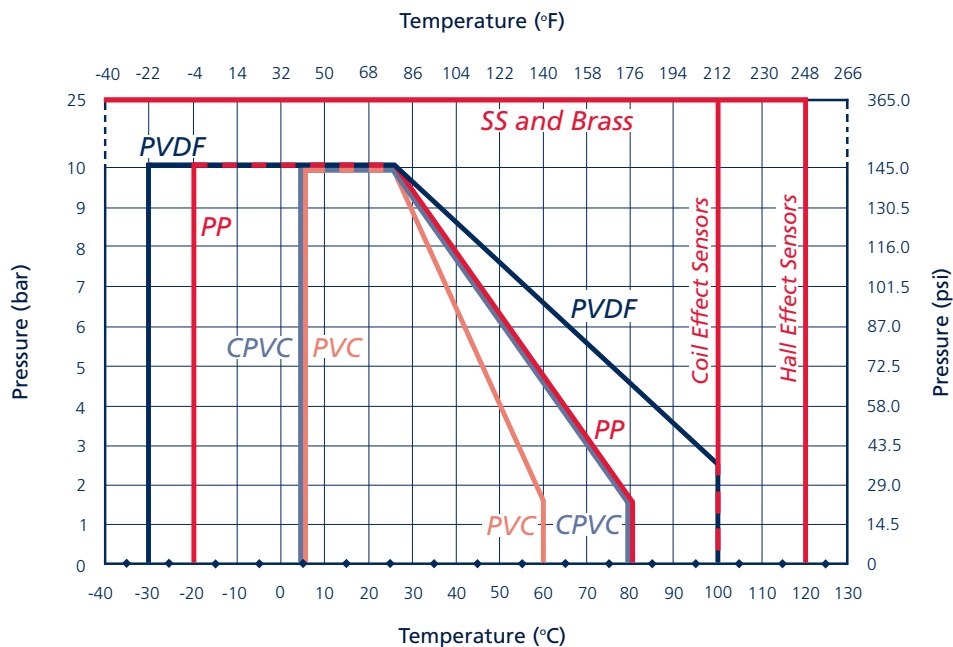

Temperature Ranges

Material	Temperature Range
PVC:	Polyvinyl Chloride 5 to 60°C (41 to 140°F)
CPVC:	Chlorinated Polyvinyl Chloride 5 to 80°C (41 to 176°F)
PP:	Polypropylene -20 to 80°C (-4 to 176°F)
PVDF:	Polyvinylidene Fluoride -30 to 100°C (-22 to 212°F)
316L SS & Brass:	Allowable temperature range is limited by the sensor's electronics Hall Sensors: -30 to 120°C (-22 to 248°F) Coil Sensors: -30 to 100°C (-22 to 212°F)