

SP Series Proportional Ball Valves

Chemline SP Series Proportional Ball Valve is designed for proportional (linear) flow control of chemicals or clean fluids. The ball is specially designed to provide linear characterized flow control 20° through 90° rotation of the handle. This valve is similar but not of the same design as other V-ball valves. It offers excellent control and C_v values higher or similar to those of diaphragm valves. With a positioning electric actuator, this becomes an inexpensive control valve.



CHEMLINE
Plastics Limited

Your Pipeline To Quality

PVC, PP, PVDF

SERIES: SP

SIZES: 1/2" – 2"

ENDS: Threaded, Socket, Butt¹
or ChemFlare™²

SEATS: Teflon® PTFE

O-Rings: EPDM, FPM (Viton®)

Excellent Flow Control

High C_v Values

Features

Linear Flow Control

Full Size Range

- 6 valves sizes 1/2" to 2" offers a large selection of C_v values

Integral Scale

- 5° increments from 0° up to 90°

High End Ball Valve Features

- Full Blocking design
- Double Stem O-Rings for safety
- Built in Tool for valve disassembly
- Teflon® seats with elastomer cushion
– Automatically compensates for seat wear or expansion
- 230 psi pressure rated (PVC and PVDF)

Low Stem Torques

- Due to floating ball design and cushioned Teflon® seats

Compact

- Space saving



Integral 90° Scale with 5° Increments

- Linear flow control and settable flow rates



¹ Butt ends for fusion to Chemline metric PP or PVDF piping.

² For ChemFlare™ end connectors, consult Chemline.

SP Series Proportional Ball Valves

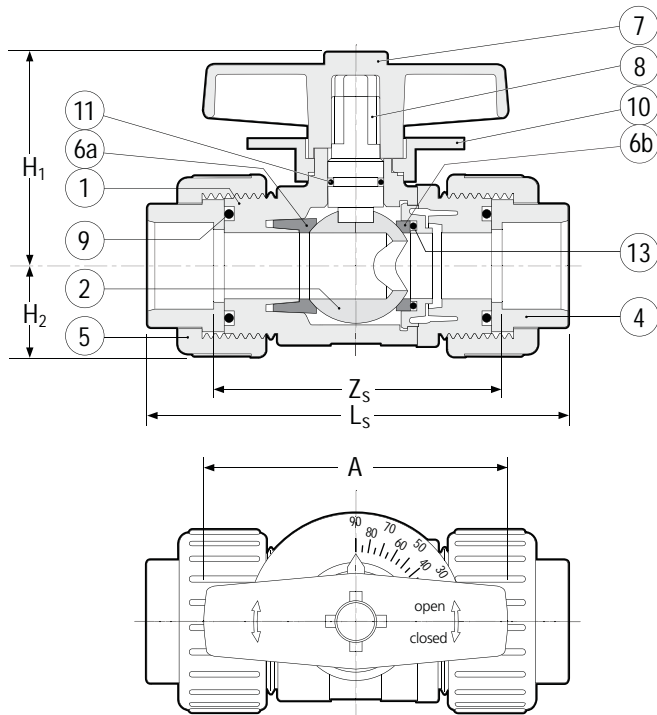

PARTS

No.	Part	Pcs.	Materials
1	Body ¹	1	PVC, PP, PVDF
2	Ball	1	PVC, PP, PVDF
4	End Connector	1	PVC, PP, PVDF
5	Union Nut	1	PVC, PP, PVDF
6a	Ball Seat ¹	1	PTFE
6b	Ball Seat ¹	1	PTFE
7	Handle	2	PVC
8	Stem ¹	1	PVC, PP, PVDF
9	Face O-Ring	2	EPDM, FPM(Viton®)
10	Position Indicator Scale	2	PVC, PP
11	Upper Stem O-Ring ¹	2	EPDM, FPM(Viton®)
12	Lower Stem O-Ring	2	EPDM, FPM(Viton®)
13	Seat Cushion ¹	2	EPDM, FPM(Viton®)

¹ Replaceable as a complete part.

DIMENSIONS INCHES

Size	PVC					PP					PVDF				
	A	Z _s	L _s	H ₁	H ₂	A	Z _s	L _s	H ₁	H ₂	A	Z _s	L _s	H ₁	H ₂
1/2"	2.68	2.76	4.02	2.01	0.87	2.68	2.72	3.86	2.01	0.91	2.68	2.72	3.86	2.01	0.85
3/4"	3.07	3.23	4.72	2.40	1.04	3.07	3.19	4.45	2.40	1.10	3.07	3.15	4.41	2.40	1.02
1"	3.46	3.43	5.16	2.76	1.18	3.46	3.35	4.76	2.76	1.30	3.46	3.31	4.72	2.76	1.14
1-1/4"	3.86	3.86	5.91	3.19	1.46	3.86	3.82	5.43	3.19	1.56	3.86	3.78	5.39	3.19	1.42
1-1/2"	4.25	3.98	6.42	3.54	1.63	4.25	3.98	5.83	3.54	1.71	4.25	3.94	6.38	3.54	1.59
2"	4.65	4.76	7.75	4.33	2.03	4.65	4.76	6.93	4.33	2.11	4.65	4.76	6.93	4.33	1.97

View from Downstream Side



60° Position

- Partially open



90° Position

- Fully open



ELECTRICALLY ACTUATED

- The metering ball valve becomes a proportional control valve with the addition of an E Series electric actuator with on-board positioner
- Thermoplastic housing and mounting bracket
- Manual override
- Position indication
- Different voltages are available

SP Series Proportional Ball Valves



WORKING PRESSURES PSI

NET WEIGHTS LB. C_v VALUES

Size	PVC			PP				PVDF				PVC	PP	PVDF	USGPM Flow at 1 psi ΔP		
	20°C	40°C	60°C	20°C	40°C	60°C	80°C	20°C	40°C	60°C	80°C					100°C	120°C
	68°F	104°F	140°F	68°F	104°F	140°F	176°F	68°F	104°F	140°F	176°F					212°F	248°F
1/2"	230	130	30	150	100	65	29	230	190	150	105	80	50	0.35	0.29	0.40	6.0
3/4"	230	130	30	150	100	65	29	230	190	150	105	80	50	0.60	0.44	0.64	11.0
1"	230	130	30	150	100	65	29	230	190	150	105	80	50	0.84	0.64	0.88	17.5
1-1/4"	230	130	30	150	100	65	29	230	190	150	105	80	50	1.50	1.04	1.54	28.0
1-1/2"	230	130	30	150	100	65	29	230	190	150	105	80	50	2.10	1.63	2.43	44.0
2"	230	130	30	150	100	65	29	230	190	150	105	80	50	3.70	2.60	3.86	59.0

Temperature Ranges: PVC 0 to 60°C (32 to 140°F), PP 10 to 80°C (50 to 176°F), PVDF -20 to 120°C (-4 to 248°F).

C_v VALUE vs. VALVE OPENING

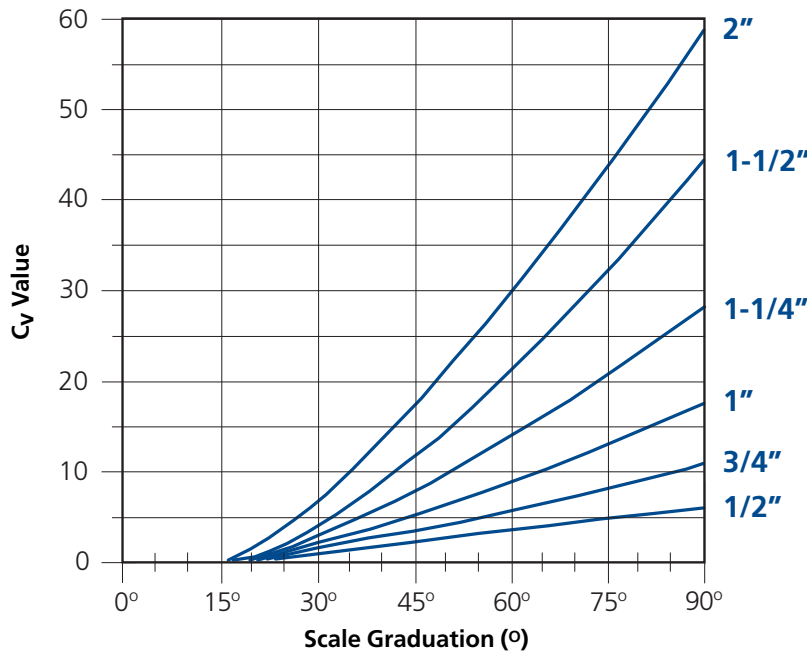

SAMPLE SPECIFICATION

1. All flow control valves, 1/2" to 2", will be Chemline SP Series proportional ball valves.
2. Body material will be PVC, PP or PVDF, and O-rings will be EPDM or FPM (Viton®).
3. Seats will be Teflon® PTFE with elastomer cushions for positive closure with minimum stem torques and automatic compensation for seat wear and expansion.
4. Body will be full blocking design with double stem o-rings for safety, rated at 230 psi maximum working pressure for PVC and PVDF and 150 psi for PP material
5. Ball will be floating design for low stem torque, molded solid with a special patented profile for linear flow control over a 90° range of handle rotation.
6. Position indicating scale will be 0° to 90° with 5° increments for fine flow control and settable flow rates.
7. End connections will be 1/2" to 2", ANSI socket, FNPT threaded, 150 lb flanged, butt fusion for Chemline metric PP or PVDF pipe or ChemFlare for Chemline Teflon tubing.

ORDERING EXAMPLE

Chemline Proportional Ball Valve			SP	A	010	E	S
Valve Material	A – PVC	B – PP	K – PVDF				
Size	005 – 1/2"	007 – 3/4"	010 – 1"				
	012 – 1-1/4"	015 – 1-1/2"	020 – 2"				
Seals	E – EPDM		V – FPM (Viton®)				
Ends	S – Socket	T – Threaded	B – Butt ¹	CF – ChemFlare™			

Example: SP Series Ball Valve, PVC, 1", EPDM seals, socket ends.

¹PP and PVDF metric butt fusion ends (1/2" to 2") connect to Chemline PP and PVDF piping systems.

VACUUM RATING

- 29.9 inches mercury

OPTIONS & ACCESSORIES

- Reduced Ends
- Electric Actuator with Positioner
 - Operates as a linear control valve



55 Guardsman Road, Thornhill, Ontario, Canada, L3T 6L2
 Tel: 905-889-7890 request@chemline.com
 Fax: 905-889-8553 www.chemline.com

Your Pipeline To Quality Valves, Piping, Flow Meters and Controls

