

INSTALLATION AND MAINTENANCE INSTRUCTIONS

For Chemline A- & Q-Series Actuator with Positioner

General:

The 4-20 mA positioner circuit board option is designed to provide precise control of actuator position through 90° of rotation or multiple 360-degree rotations for multi-turn valves.

Refer to attached drawings and proceed as follows:

Calibration:

Calibration:

Do not manually override the actuator out of its quadrant. If the actuator is out of quadrant, follow the directions below. All other settings should be correct provided that nothing else has been modified or adjusted.

Power actuator to the fully closed position by applying 120VAC to terminals 1 and 4 at location J1. Re-adjust closed limit micro switch now, if necessary. If the potentiometer does not read approximately 95 ohms between terminals 1 and 2 at location J1, or 500 ohms at midpoint for multi-turn, then adjust the ohm reading by loosening the 3 #8-32 set screws on the large gear on the actuator shaft and rotate it (and therefore the potentiometer gear) until the desired value is obtained, then retighten the 3 screws. Install 4-20 mA input signal to location J3.

Zero adjustment:

Apply a fully closed signal to the positioner's input equal to 4 mA. The actuator should cycle until the minimum signal position limit switch is tripped, stopping the actuator. Adjust the "zero" adjustment (drawing #0003PB, CW for less closed, CCW for more closed) until the actuator stops in the fully closed position and the red indicator LED is off.

- a) If the red LED is on, turn the "zero" adjustment clockwise until the LED just turns off.
- b) If the red LED is off, turn the "zero" adjustment counter clockwise until the LED is on, then clockwise until the LED just turns off.

Calibration & Adjustment Instructions A- & Q- Series Actuator w/Positioner**Range adjustment:**

Apply a fully open signal to the positioner's input equal to 20 mA. The actuator should cycle until the maximum signal position limit switch is tripped stopping the actuator. Adjust the "range" adjustment (drawing #0003PB, CW for less open, CCW for more open) until the actuator stops in the fully open position and the green indicator LED is off.

- a) If the green LED is on, turn the "range" adjustment clockwise until the LED just turns off.
- b) If the green LED is off, turn the "range" adjustment counter clockwise until the LED is on, then clockwise until the LED just turns off.

NOTE: It may be necessary to repeat steps A&B when calibrating the "zero" and "range" adjustment to ensure proper calibration.

NOTE: If unit is calibrated for 0 – 10 VDC input, adjustment procedure remains the same, only the control signal changes to 0 - 10 VDC.

NOTE: For reverse acting (20 mA closed, 4 mA open) factory modifications are required, however adjustment procedure remains the same.

Calibration & Adjustment Instructions A- & Q- Series Actuator w/Positioner

PERFORMANCE CHART Positioner Mounted in Typical Actuator

<p><i>Independent Linearity</i> (The maximum deviation of the actual characteristic from a straight line).</p>	0.5% of span
<p><i>Resolution</i> (Smallest possible change in valve position)</p>	0.7% of span
<p><i>Deadband</i> (The maximum range through which the input signal can be varied without initiating a change in output shaft position. Adjustable via anti-hunt control).</p>	0.5% min. of span
<p><i>Hysteresis</i> (The maximum difference in output shaft position for a given input signal during a full range traverse in each direction).</p>	1.2% of span
<p><i>Temperature Limits</i> (Ambient)</p>	-40° - 115°F
<p><i>Duty Cycle</i></p>	Specify 75%
<p><i>Characteristic</i> (Input/Output relationship)</p>	Linear

Calibration & Adjustment Instructions A- & Q- Series Actuator w/Positioner**PERFORMANCE CHART**
Positioner Mounted in Typical Actuator***Current Draw***5 Watts plus
Actuator current drain***Load Resistance***150 ohms for 10-50 mA signal
320 ohms for 4-20 mA signal
1100 ohms for 1-5 mA signal***Adjustments***Zero -25% of span
Range -25% of span
Anti-hunt control 0.25 to 10% signal***Feedback Potentiometer***

1000 ohms

OptionsExtra Limit Switches
Heater/Thermostat
Mechanical Brake/Butterfly Valve Application
Direct or Reverse Acting
Dual Potentiometer
Split Ranging

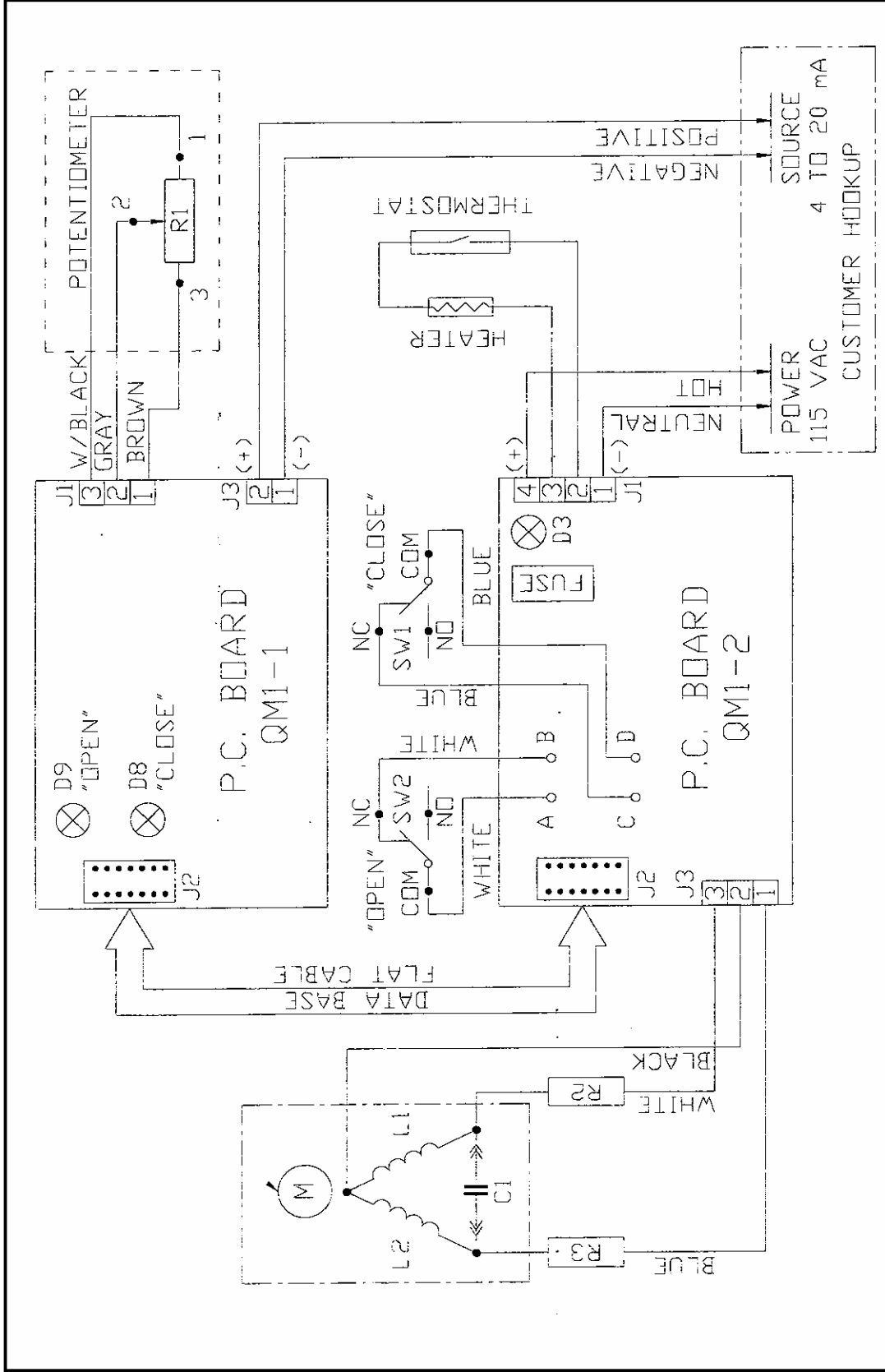

NOTE:
 For reverse acting (4mA open, 20mA closed), connect wires from potentiometer as follows: W/Black to terminal #1, brown to terminal #3, J1 on board QM1-1.
 Reset cam on SW1 to open position, and cam on SW2 to closed position.

THIS DRAWING AND ALL INFORMATION HEREON IS THE PROPERTY OF ASAH/AMERICA. ANY COPYING, REPRODUCTION OR UNAUTHORIZED USE IS FORBIDDEN WITHOUT WRITTEN CONSENT.

DR	NAME	DATE
DR	KENICHI MIYAZAKI	8/3/01
APP'D	DAVE HURLEY	8/3/01
PROD	LEO LESTER	8/3/01
WO# / CO#		

Full Wiring Diagram A-Series w/ Positioner

SIZE	A	DWG. NO.	0006PB	REV	A
SCALE	NTS	SHEET	OF		

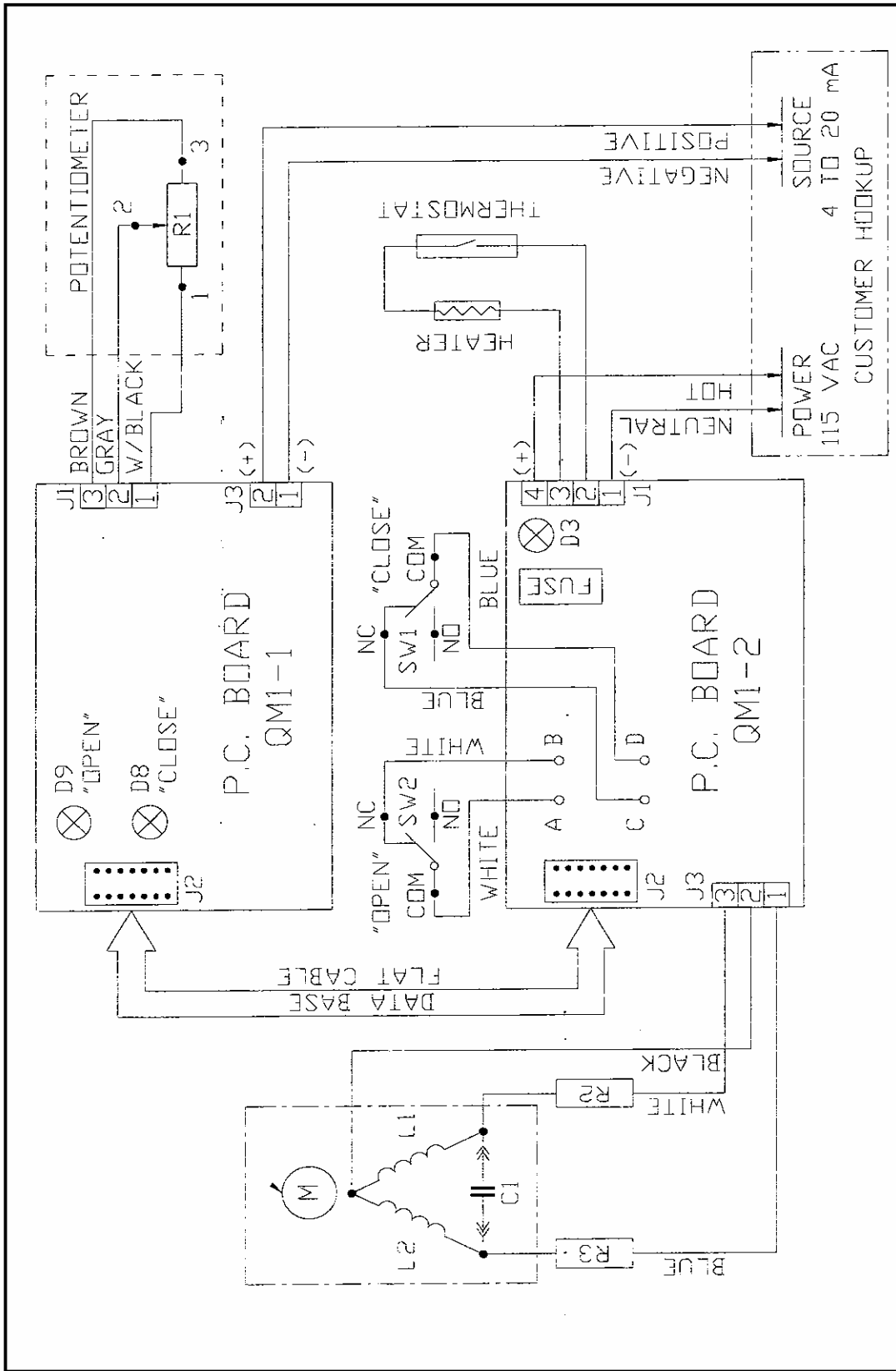

NOTE:

For reverse acting (4mA open, 20mA closed), connect wires from potentiometer as follows: W/Black to terminal #3, brown to terminal #1, J1 on board QM1-1.
 Reset cam on SW1 to open position, and cam on SW2 to closed position.

THIS DRAWING AND ALL INFORMATION HEREON IS THE PROPERTY OF ASAHI/AMERICA. ANY COPYING, REPRODUCTION OR UNAUTHORIZED USE IS FORBIDDEN WITHOUT WRITTEN CONSENT.

NAME	DATE
DR. KENICHI MIYAZAKI	8/3/01
APP'D. DAVE HURLEY	8/3/01
PROD. LEO LESTER	8/3/01
WO# / CO#	

**Full Wiring Diagram
Q-Series Actuator w/ Positioner**

SIZE	A	DWG. NO.	0006PB	REV	A
SCALE	N.T.S.	SHEET	OF		