

MAINTENANCE INSTRUCTIONS

For Chemline Globe Valves Sizes 1/2" - 2"

Maintenance (Sizes 1/2" to 2")

Refer to **ASSEMBLY DRAWING GV-01(A)**. And proceed as follows:

1. Remove bonnet and stem assembly (2 through 5) by unscrewing gland nut (6). The complete stem assembly should lift out of the valve body.
(Note: make sure there is no pressure in line prior to removing valve.)
2. The stem (4) is removed from the bonnet assembly by first removing the handwheel (3) by unscrewing nut (9). Loosen the stem packing (8) and inspect for excessive wear and cracking.
3. Lubricate the seal (7) before replacing the shaft (4). Dow Corning III silicone compound recommended.
4. Inspect the body seat (1) and disc seat (5) for excessive wear and pitting. Pitting is caused by foreign objects being jammed between the sealing surfaces when closing the valve. If the disc seat (5) is damaged, replace the part.
Important: If the body seat is damaged replace the complete valve.
5. To reassemble valve, reverse steps 1 to 4 above.

(NOTE) When replacing the stem assembly back into the valve body, be sure that the stem NOT in the closed position. If it is, the stem may be over extended and could damage the body seat when the bonnet is re-tightened.

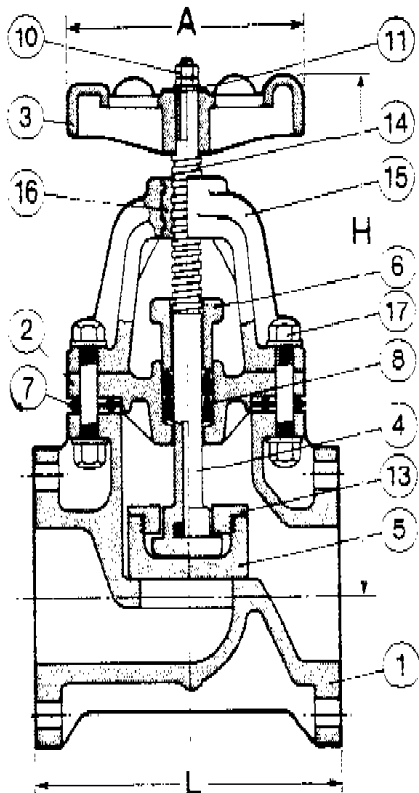
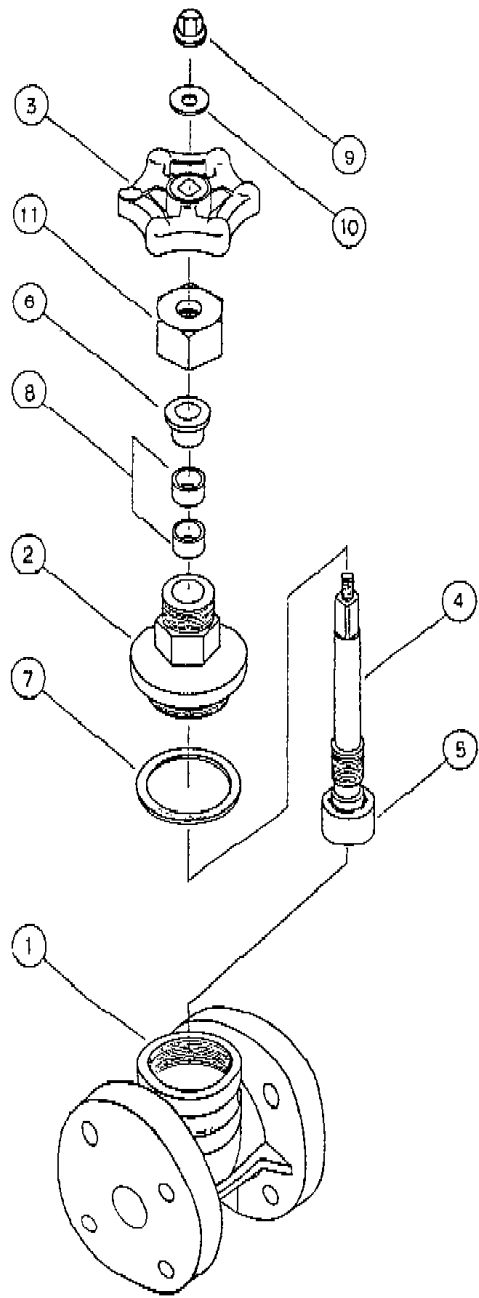

PART	DESCRIPTION	QTY	MATERIAL
1	BODY	1	PVC/PP
2	BONNET	1	PVC/PP
3	HANDWHEEL	1	PP
4	STEM	1	PVC/PP
5	DISC	1	PP
6	GLAND	1	PVC/PP
7	BONNET SEAL	1	EPDM
8	STEM PACKING	2	EPDM
10	NUT	1	PVC
11	WASHER	1	PVC
12	GLAND NUT	1	PVC/PP
13	DISC RETAINER	1	PP
14	STEM TOP	1	BRASS
15	YOLK	1	PP
16	YOLK SLEEVE	1	BRONZE
17	BOLT & NUT	8	SS 304
18	STUD & NUT	2	SS 304

CHEMLINE PLASTICS

CHEMLINE

TITLE: CHEMLINE GLOBE VALVE SIZES

REFERENCE: 1/2" - 2"

SCALE	DATE
DR. BY	
CHKD. BY	
APP. BY	

DWG. NO. GV01(A) REV. 0